

Technical Specifications HSR-048/055/065

Standard type

		HSR048A1-N/S*	HSR055A1-N/S*	HSR065A1-N/S*
Total arm length (J1: No. 1 arm + J2: No. 2 arm)		205+275=480mm	275+275=550mm	375+275=650mm
Motion angle and stroke	J1 (No.1 axis)	±130°		
	J2 (No.2 axis)	±143.5°	±150°	
	Z (No.3 axis) *	*=10 : 100mm		
		*=20 : 200mm		
*=32 : 320mm				
T (No.4 axis)	±360°			
Axis combination		J1 (No.1 axis) + J2 (No.2 axis) + Z (No.3 axis) + T (No.4 axis)		
Maximum payload		8kg		
Cycle time *2		0.28sec	0.28sec	0.31sec
Maximum joint speed	J1	450deg/sec	450deg/sec	450deg/sec
	J2	785deg/sec	785deg/sec	785deg/sec
	Z	10:1700mm/sec,20:2300mm/sec,32:2475mm/sec		
	T	2500deg/sec		
Position repeatability (Value at the constant ambient temperature.)	J1+J2	±0.01mm	±0.012mm	
	Z	±0.01mm		
	T	±0.004°		
Maximum pressure input (downward)		98N (1 second or less)		
Maximum allowable inertia moment		0.12kgm ²		
Position detection method		Absolute encoder		
Drive motor / brake		All-axis servo motor / Z- and T-axis brake		
User air piping		4 systems (φ4×2、φ6×2)		
User signal lines		· 19 (for proximity sensor signals, etc.) · Ethernet(8) *Option		
Air source	Normal pressure	0.05~0.35MPa		
	Max. allowable pressure	0.59MPa		
Airborne noise (A-weighted equivalent continuous sound pressure level)		80dB or less		
Weight		Approximately 31 kg	Approximately 31.5 kg	Approximately 32 kg

1.An asterisk [] in a model name indicates Z-axis stroke

*2 Time required for a robot to move a 2 kg payload between two points 300 mm apart at a height of 25 m

*3 Position repeatability is the precision at constant ambient temperature.

External Dimensions for Standard Type Unit: mm

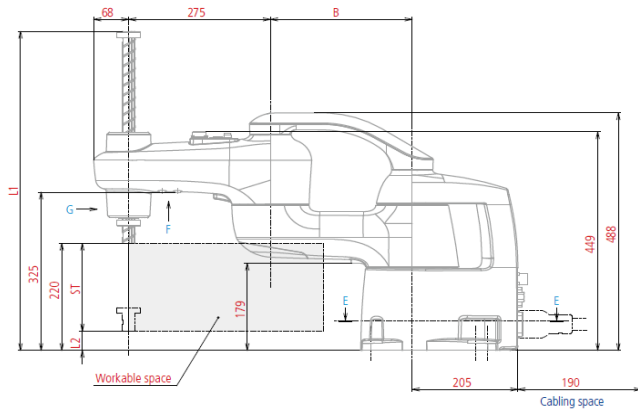

Model	A	B	C	D	E
HSR048A1-N*	480	205	164.4	287°	406.53
HSR055A1-N*	550	275	142.4	300°	364.32
HSR065A1-N*	650	375	194.0	300°	287.62

Positions of existing wiring and piping securing screws

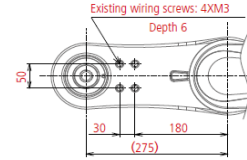

Detailed drawing of end-effector mounting face (View G)

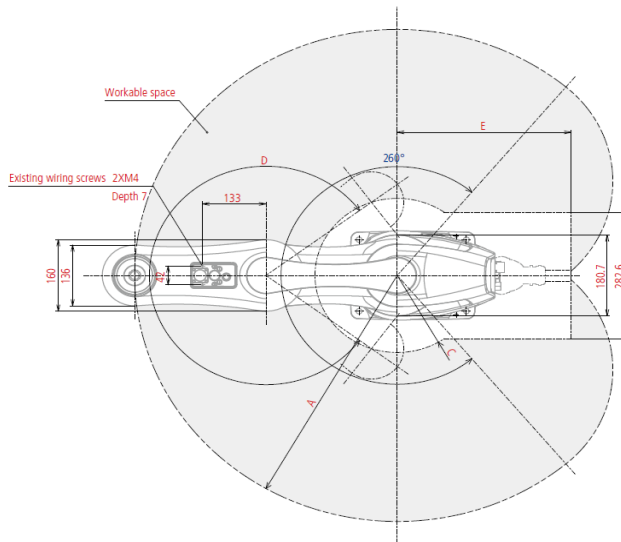
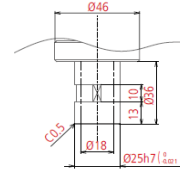

Z-axis stroke : ST (mm)	L1	L2
* =10 : 100	555.2	120
* =20 : 200	655.2	20
* =32 : 320	775.2	-100 ^{Note 1}

Note 1: Be noted that if Z is 320mm, the lowest point of the Z-axis will achieve a position lower than the base mounting face.

Flange (Option) Mounting Drawing

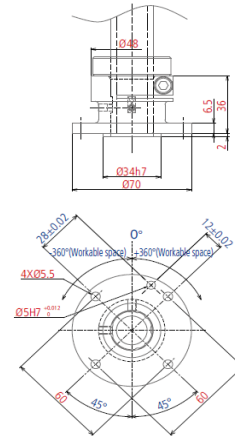

Base Mounting Dimensions (E-E cross section)

